

Adaptive Antennas for the Wireless Future: Design, Analysis, and Performance Evaluation of Frequency Reconfigurable

Prem Nath Suman¹, Gajendra Kant Mishra²

Abstract – This research paper covers a comprehensive investigation into the design, analysis, and performance evaluation of frequency reconfigurable antennas. The relentless advancement of wireless communication technology has necessitated the development of antennas that can adapt seamlessly to a wide range of operating frequencies. The proposed antenna design incorporates a circular ring configuration with a PIN diode for dynamic frequency tuning. The reconfigurable element allows for versatile operation across multiple frequency bands, avoiding the requirement for separate antennas and simplifying system integration. The performance evaluation encompasses key parameters such as radiation pattern, gain, bandwidth, and efficiency, assuring optimal performance across the specified frequency range. The measured and simulated results validate the accuracy and effectiveness of the recommended structure. The research findings contribute to the state-of-the-art advancements in frequency reconfigurable antenna engineering, enabling efficient wireless communication systems for several applications, such as cellular networks, WLANs, satellite communication systems, and cognitive radio networks.

Keywords – Frequency reconfigurable antenna, PIN diode, spectrum, band, circular patch, ring.

I. INTRODUCTION

The relentless expansion of wireless communication systems has spurred the demand for antennas that can seamlessly adapt to a wide range of operating frequencies [1]. Frequency reconfigurable antennas have emerged as a promising remedy to address this demand, offering dynamic frequency tuning and effective utilization of the available spectrum. This research paper focuses on the design, analysis, and performance assessment of frequency reconfigurable antennas, aiming to contribute to the state-of-the-art advancements in this field. In the past, traditional antenna designs required separate antennas for each specific frequency band, resulting in complex and bulky systems [2]. However, frequency reconfigurable antennas offer a paradigm shift by allowing dynamic adjustment of the operating frequency.

This flexibility eliminates the need for multiple antennas, simplifies system integration, and reduces overall costs [3-4].

Article history: Received September 10, 2023; Accepted December 16, 2023.

¹Prem Nath Suman is a research scholar in the Department of Electronics & Communication Engineering at Birla Institute of Technology, Mesra, Ranchi, India. E-mail: prem.pns@gmail.com

²Gajendra Kant Mishra is a faculty in the Department of Electronics & Communication Engineering at Birla Institute of Technology, Mesra, Ranchi, India 835215. E-mail: gkantm@gmail.com

To achieve frequency reconfigurability, various techniques have been explored, including the use of reconfigurable elements, switchable resonators, and tunable materials. These methods enable the antenna to adapt its resonance to different frequency bands, catering to the diverse requirements of modern wireless communication standards [4-5]. By dynamically switching between frequencies, these antennas can support multi-band operations and effectively handle frequency-hopping applications.

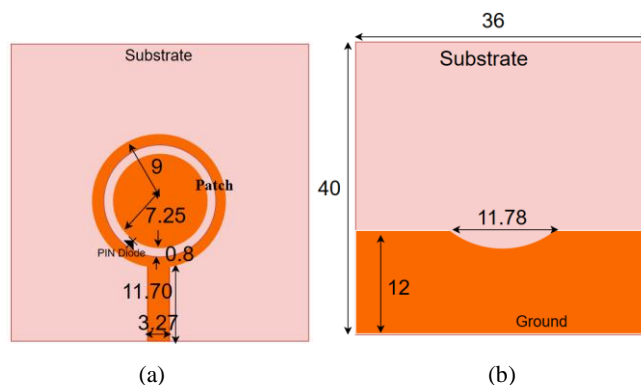

Fig. 1. Overall dimensions (all in mm) and geometry of the frequency reconfigurable antenna: (a) top view, (b) bottom view

The performance of frequency reconfigurable antennas is a critical aspect of their design. Key parameters such as radiation pattern, gain, bandwidth, and efficiency must be carefully considered to ensure optimal performance across the desired frequency range [6]. The state-of-the-art research in this area focuses on enhancing these parameters while maintaining compact antenna size, low power consumption, and robustness in varying environments.

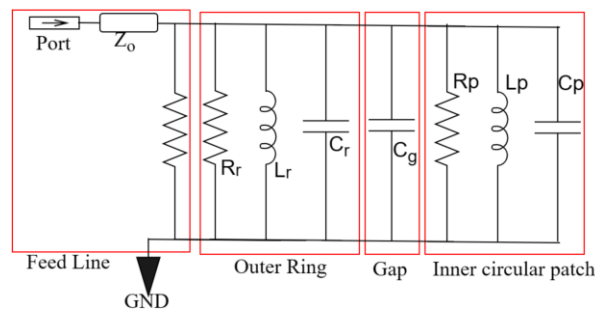

Fig. 2. Equivalent circuit models of proposed antenna without PIN diode

Moreover, the applications of frequency reconfigurable antennas are vast and encompass various domains. They find utility in wireless communication systems that require agile

operation over multiple frequency bands, including cellular networks, WLANs, and satellite communication systems [7]. Furthermore, frequency reconfigurable antennas are highly valuable in dynamic spectrum access scenarios, such as cognitive radio networks, where efficient spectrum utilization and interference management are critical [8].

A novel differential frequency reconfigurable antenna, utilizing two pairs of vertical arms forming dipoles, is introduced in [9]. The antenna features a feeding structure, mode switching arrangement, and PIN diodes. By toggling the PIN diodes, the antenna resonates at 3.5 and 5.5 GHz, maintaining identical effective radiation parts and similar radiation patterns, the antenna is structurally simple and exhibits a broad bandwidth.

The measured -10 dB impedance bandwidths are also well satisfied. [10] Presents a frequency-reconfigurable microstrip slot antenna with six distinct frequency bands ranging from 2.2 to 4.75 GHz. Employing five RF p-i-n diode switches within the slot enables seamless frequency switching. To reduce antenna size by 33%, both the feed line and slot are bent. Integration of the biasing circuit into the ground plane minimizes parasitic effects.

A compact planar loop-monopole reconfigurable antenna designed for mobile handsets [11]. A unique strategy utilizes loop mode for low and high bands (LTE700, GSM850, GSM900; LTE2300, WLAN, LTE2500) and strip monopole mode for the medium band (DCS, PCS, UMTS), achieving nona-band coverage for 2G/3G/4G within limited space. Utilizing only one p-i-n diode with a simple bias circuit minimizes insertion loss. The antenna's compact structure makes it suitable for wideband smartphone applications.

Aperture Fed miniaturized microstrip patch antenna for frequency reconfigurability [12], featuring two PIN diodes at upper substrate positions was implemented. Aperture feed, compressed between upper and lower substrates, reduces spurious waves at higher frequencies, making the antenna suitable for X-band applications. Reconfigurability is achieved by controlling the switching of two modelled PIN diodes, enabling frequency switching from 11.58 GHz (both diodes On) to 11.66 GHz (both Switches Off). [13] Presents a planar monopole antenna for WiMAX devices with two frequency-tunable bands at approximately 2.4 GHz (lower) and 3.4 GHz (higher). Two varactors on radiating branches, equipped with innovative DC-biasing circuits, enable continuous tuning of bands with corresponding DC-bias voltages. The lower band spans 2.3–2.69 GHz, while the higher band covers 3.3–3.8 GHz for WiMAX.

A compact loop antenna with independent frequency tuning was designed [14], featuring a feed line connected to a 50Ω coaxial probe and four resonating arms. The aggregated tunable bands provide a wide bandwidth, with good impedance bandwidths.

This research paper aims to contribute to the advancement of frequency reconfigurable antennas by exploring circular ring design approaches, analysing their performance characteristics, and evaluating their suitability for specific applications. By investigating the latest state-of-the-art techniques, we strive to push the boundaries of antenna engineering, unlocking new possibilities for efficient wireless communication systems.

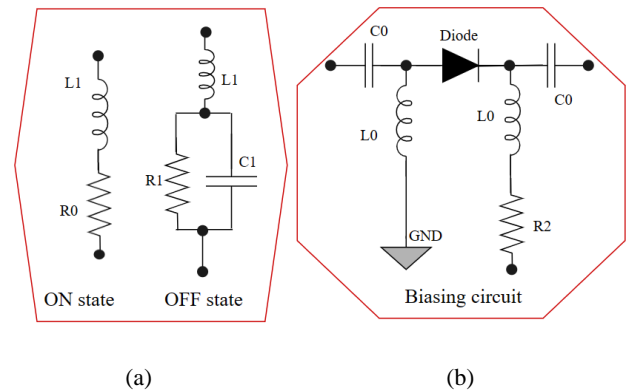

Fig. 3. (a) Equivalent circuit models of PIN diode at On and Off state, (b) Biasing Circuit of the PIN diode

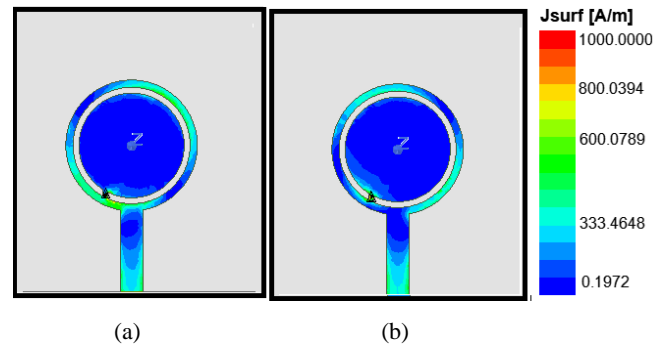

Fig. 4. Current density of antenna when diode is on: (a) 3.38 GHz, (b) 4.13 GHz

II. ANTENNA GEOMETRY AND DESIGN

The frequency reconfigurable antenna proposed in this research paper is designed on an FR-4 substrate with a thickness of 1.6 mm. The substrate exhibits a dielectric constant (ϵ_0) of 4.4 and a loss tangent (δ) of 0.019. The overall dimensions (all in mm) of the antenna are illustrated in Fig. 1. The antenna structure comprises an upper patch that includes a ring connected to the feed line, within this ring, a circular patch is designed. The choice of a circular patch over a rectangular one in our research was purposeful, driven by considerations aligned with our study's objectives. The circular geometry provides inherent symmetry, minimizing edge effects and facilitating a more straightforward analysis of results. This choice aims to improve frequency performance, reduce cross-polarization, and enhance the overall performance parameter of the antenna system. While a rectangular patch may be easier to fabricate, the technical advantages of a circular patch, including its uniform radiation pattern and reduced cross-polarization, align with our research goals, ensuring optimal performance for the intended application. The equivalent circuit of the antenna structure without the pin diode is demonstrated in the Fig. 2. C_g is the capacitance generated due to the gap between the inner circular patch and the ring. Adding a PIN diode in the gap of the antenna structure enables frequency reconfigurability by altering the capacitance (C_g).

The PIN diode's controllable impedance modifies the gap, affecting the resonant frequency of the antenna. This dynamic adjustment enhances the antenna's versatility for different

frequency bands. The reconfigurable element offers the ability to adjust the antenna's resonant frequency, allowing for dynamic frequency operation.

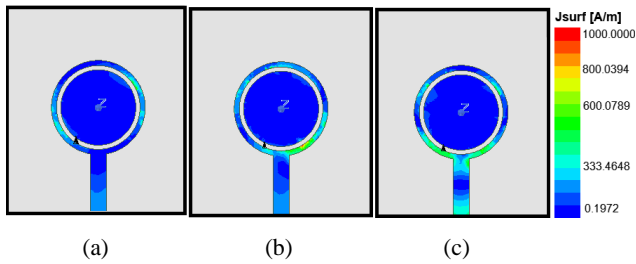

Fig. 5. Current density of antenna when diode is off: (a) 3.02 GHz, (b) 3.66 GHz, (c) 6.47 GHz

To achieve a high bandwidth, a partially ground plane is employed. The ground plane includes a defective ground structure with a round slot. The choice of a ground structure with a partial round slot in our structure is driven by the need for compactness, impedance matching, and controlled radiation pattern modification. The round slot aids in smoother impedance matching and contributes to achieving desired bandwidth and resonant frequency characteristics. The partial nature of the slot allows for targeted adjustments, enhancing the antenna's performance for specific criteria. This decision is part of a comprehensive optimization process aligned with the unique requirements. This configuration aids in widening the antenna's impedance bandwidth, ensuring efficient transmission and reception across multiple frequency bands. During the fabrication process, measured data is collected from the prototype to assess the antenna's performance.

The collected data is then compared with simulated results obtained through the Ansys-HFSS software. The antenna simulation in HFSS involved precise geometry definition, material properties specification, and careful configuration of electromagnetic parameters. The simulation settings, including frequency range and mesh density, were optimized for accurate analysis, with post-processing focusing on key performance metrics such as radiation patterns and impedance matching. HFSS was chosen for its robust capabilities in providing a comprehensive evaluation of the antenna's behaviour.

The comparison reveals an excellent fit between the measured and simulated data, validating the accuracy of the proposed design. Some of minor discrepancies may exist between the measured and simulated results due to various factors, including the measuring methodology, presence of material particles, connection losses of connectors, biasing circuit, and fabrication faults. These factors can introduce slight shifts and changes in the antenna's performance characteristics. The measurement setup is demonstrated in Fig. 8.

However, rigorous measures have been taken to minimize such effects and ensure the accuracy of the overall analysis. By incorporating the frequency reconfigurability feature, along with the defective ground structure and the round slot, the proposed antenna design achieves good performance. Achieving high gain for any antenna with high bandwidth is very challenging task [15]. The research focuses on

demonstrating the feasibility and effectiveness of the antenna for dynamic frequency applications, making it suitable for a wide range of wireless communication systems.

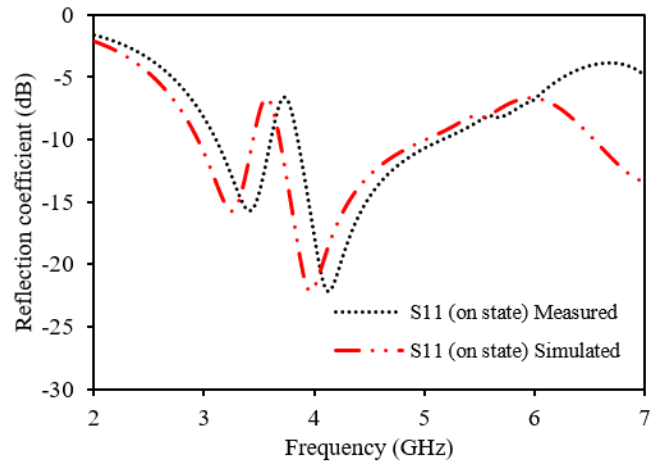

(a)

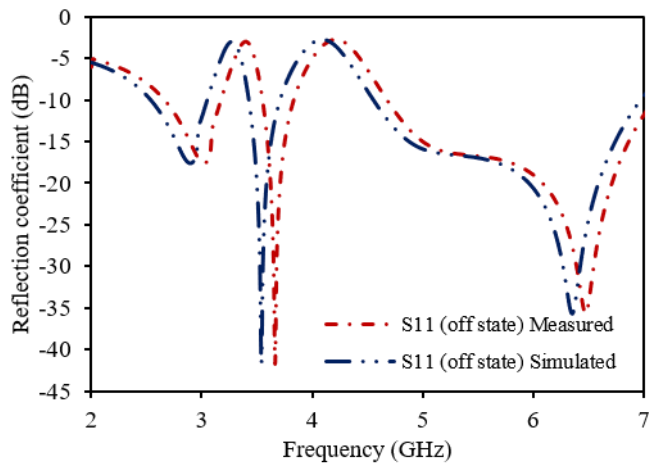

(b)

Fig. 6. Simulated and measured reflection coefficient of: (a) on state of PIN diode, (b) off state of PIN diode

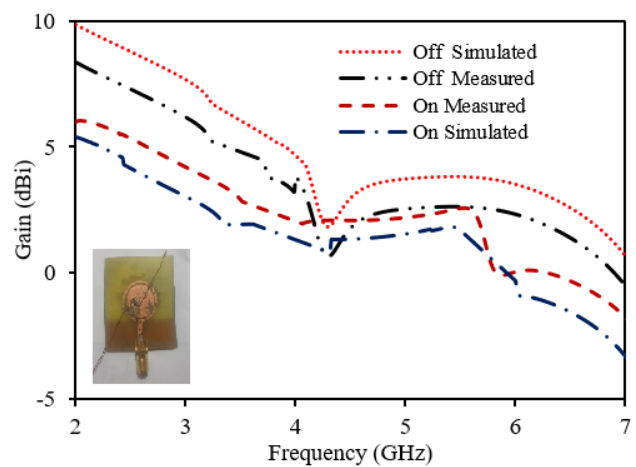

Fig. 7. Simulated and measured gain of antenna at on and off state of PIN Diode

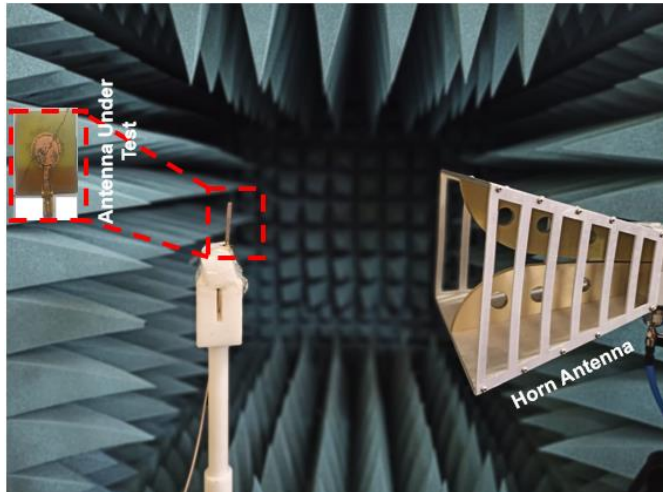
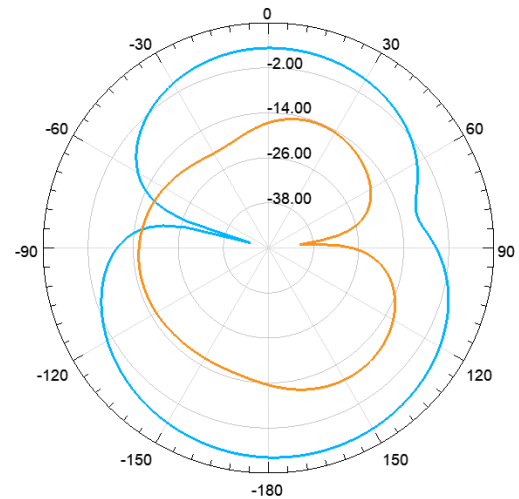

Fig. 8. Measurement Setup of the proposed antenna

III. ANALYSIS OF RECONFIGURABLE ANTENNA

The PIN diode from the BAP-65 family, which can transition between on and off states, is the optimum choice for our antenna. Fig. 3 (a) depicts a on and off switching state comparable circuit diagram the BAPS 65-02-115 datasheet contains exact values for the resistor, inductor, and capacitor indicated in the diagram, however Fig. 3(b) shows the biasing circuit of the PIN diode where C0 are the DC blocking capacitors at both ends of the diode, L0 indicated the RF choke inductors with appropriate resistance. A diode with low input resistance allows current to flow easily when it's turned on. This makes it an efficient conductor, ensuring smooth electrical signal transmission into connected circuits or components. In the "on" state, the PIN diode establishes electrical continuity between the outer ring and the inner circle in the antenna structure. This connection enhances the surface current distribution by allowing current to flow more freely between the two elements. The increased current distribution results in improved antenna performance and altered radiation characteristics, as illustrated in Fig. 4. This results in resonating frequencies of 3.38 GHz and 4.13 GHz, which expand the original frequency range of (3.11 to 3.61) GHz and (3.85 to 5.18) GHz, respectively. The bandwidth percentages achieved are 14.88% and 29.45% illustrated in Fig. 6 (a). The corresponding gains of the antenna at these resonating frequencies are measured to be 3.33 dBi and 2.07 dBi which is demonstrated in Fig.7.

When the diode is in the "off" state, a high-resistance route and a capacitor are utilized to close the circuit in the antenna structure, creating an impediment to current flow through the circular patch. This configuration isolates the inner circle from the outer ring, inhibiting the surface current distribution as illustrated in the surface current distribution diagram in Fig. 5. The electrical connection with the inner circle is broken, leads to a different set of resonating frequencies for the antenna. The resonant frequencies obtained in this configuration are 3.02 GHz, 3.66 GHz, and 6.47 GHz, covering the frequency bandwidth from (2.83 to 3.18) GHz, (3.55 to 3.85) GHz and (4.68 to 7.07) GHz respectively, resulting in bandwidth percentages of 11.65%, 8.10%, and 40.68%, respectively clearly shown in Fig. 6(b).



(a)

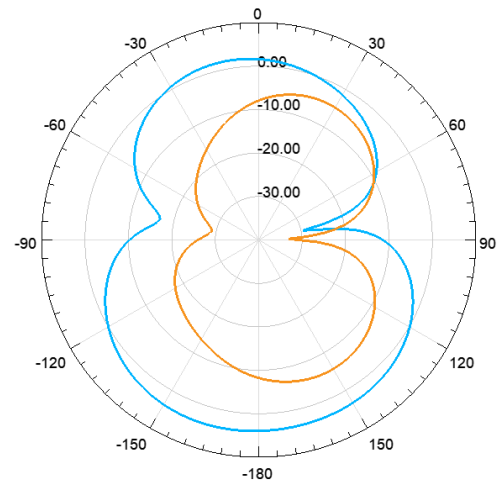

(b)

Fig. 9. Radiation pattern of frequency reconfigurable antenna when diode is on state: (a) 3.38 GHz, (b) 4.13 GHz

Fig.7 shows the gains of the antenna at these three resonating frequencies. 7.6 dBi, 5.5 dBi, and 2.3 dBi respectively are the gain at 3.02 GHz, 3.66 GHz, and 6.47 GHz. Fig. 6(a),(b) presents the simulated and measured reflection coefficients of the antenna for both the "on" and "off" states of the PIN diode. The reflection coefficient curves demonstrate the antenna's performance and its ability to achieve a good match with the operating frequencies.

It is observed that the measured results closely align with the simulated results, validating the accuracy of the design. The VSWR value of the antenna at both on and off state is also in between the specified range. Additionally, Fig. 7 illustrates the simulated and the measured gain characteristics of the antenna for both the "on" and "off" states.

The plot demonstrates the antenna's radiation efficiency at different frequencies. It is evident that the gain values vary based on the resonating frequencies, reflecting the antenna's ability to adapt and perform optimally in different frequency bands. The measured gain values validate the antenna's performance at different resonating frequencies.

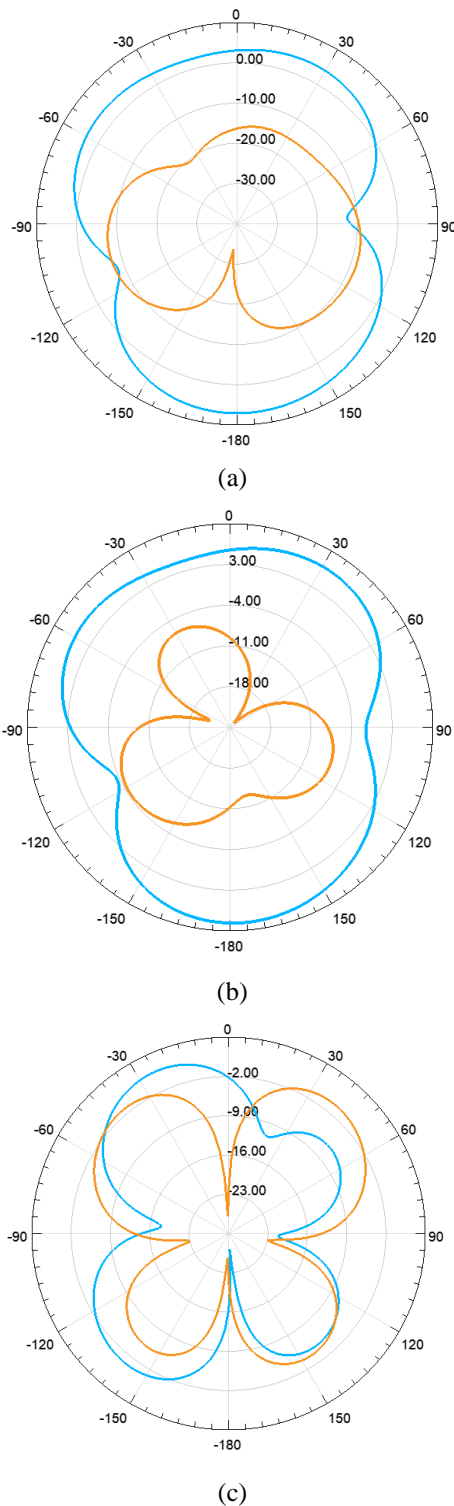

Fig. 10. Radiation pattern of frequency reconfigurable antenna when diode is off state: (a) 3.02 GHz, (b) 3.66 GHz, (c) 6.47 GHz

Higher gain values indicate improved radiation efficiency and signal strength, which are crucial factors for reliable wireless communication. The radiation pattern of the antenna when the diode is in on condition is plotted in the Fig. 9.

The analysis of the reconfigurable antenna incorporating a PIN diode has demonstrated its ability to adapt its resonating frequencies and provide versatile operation within the desired frequency range. The measured and simulated results of the

reflection coefficients and gain characteristics validate the antenna's performance in both the "on" and "off" states of the PIN diode. The achieved bandwidth percentages indicate the ability of the antenna to cover a wide frequency band, The findings of this analysis contribute to the understanding and advancement of frequency reconfigurable antenna designs, offering potential applications in diverse wireless communication systems. The Fig. 9 and Fig. 10 depict the radiation patterns of an antenna at different frequencies (3.38, 4.13) GHz when diode is "on" and (3.02 , 3.66 , 6.47) GHz when diode is in "off" states. Interestingly, in both states, the antenna exhibits almost a bidirectional radiation pattern, meaning it effectively transmits and receives signals in two opposite directions, indicating a consistent and satisfied design characteristic of the reconfigurable antenna. This behavior suggests that the antenna is capable of maintaining its almost bidirectional radiation pattern regardless of the diode's state, which can be advantageous for applications requiring signal transmission and reception from multiple directions. Table. 1. Provides the comparisons of the proposed work with previous latest relevant work. To the best of our knowledge, the gain of the proposed antenna is about 7.6 dBi better than most relevant works with 5 different resonating frequencies at the two different switching state of single PIN diode.

Future enhancements for the circular patch reconfigurable antenna could involve exploring advanced materials with tunable properties, integrating machine learning algorithms for real-time optimization, investigating metamaterials for unconventional functionalities, incorporating MIMO techniques for improved communication performance, and fostering interdisciplinary collaborations to leverage emerging technologies for further advancements.

IV. CONCLUDING REMARK

In conclusion, the analysis of the reconfigurable antenna utilizing a PIN diode has demonstrated its capability to dynamically adjust resonating frequencies, enabling versatile operation across a wide frequency range. The measured results have validated the antenna's performance in both the "on" and "off" states, with achieved bandwidth percentages indicating efficient spectrum utilization. In on state antenna dual resonance at 3.38 GHz and 4.13 GHz with the acceptable gain of 3.33 dBi and 2.07 dBi are obtained. At the off state antenna resonates at are 3.02 GHz, 3.66 GHz, and 6.47 GHz with the gain of 7.6 dBi, 5.5 dBi, and 2.3 dBi respectively. The antenna's dual resonances at 3.38 GHz and 4.13 GHz are applicable for Wi-Fi and Bluetooth, while in the off state, resonances at 3.02 GHz, 3.66 GHz, and 6.47 GHz with varying gains cater to 4G/5G cellular communication and satellite/radar applications, showcasing its versatility across diverse frequency bands for multifunctional communication devices. The findings contribute to the advancement of frequency reconfigurable antenna designs, showcasing the potential of using PIN diodes for adaptive wireless communication systems. This antenna paves the way for the development of adaptable and efficient antennas that can enhance signal reliability, support flexible communication systems, and operate across multiple frequency bands.

TABLE 1
COMPARISONS WITH LATEST RELEVANT WORKS

Ref no.	Dimension	No of resonating freq.	Operating band (GHz)	BW	No of Switch used	Maximum gain (DBi)
[9]	(50 X 50) mm ²	2	2.89-4.07/ 5.1-6.9	33% / 19.8%	4	3.7
[10]	(50 X 46 X 1.52) mm ³	6	---	(380, 370, 360, 360, 360, 370) MHz	5	4.1
[11]	(60 X 10 X 0.8) mm ³	3	0.698- .0960/ 2.30-2.69/ 1.71- 2.17	31.6%/ 15.63%/ 27.54%	1	1.45
[12]	(35 X 25X 1.6) mm ³	4	11.39-11.75/ 11.44-11.81/ 11.44-11.81/ 11.47-11.83	3.11% / 3.18% / 3.18% / 3.09%	2	---
[13]	(40 X 35 X 0.8) mm ³	2	2.4/3.5	15.6% / 14.1%	2	1
[14]	(25 X 10 X 0.2) mm ³	4	0.698- 0.96/ 1.6-2.6 / 3.4-3.8 / 5-6	31.6%/ 47.6%/ 11.1% / 18.1%	4	2.1
Proposed Paper	(40 X 36 X 1.6) mm ³	5	3.11-3.61/3.85-5.18/ 2.83-3.18/ 3.55-3.85/ 4.68-7.07	14.88%/ 29.45%/ 11.65%/8.10%/ 40.68%	1	7.6

REFERENCES

- [1] X. Liu, Y. Liu and M. M. Tentzeris, "A Novel Circularly Polarized Antenna With Coin-Shaped Patches and a Ring-Shaped Strip for Worldwide UHF RFID Applications", *IEEE Antennas and Wireless Propagation Letters*, vol. 14, pp. 707-710, 2015.
- [2] K. N. Ketavath, "Enhancement of Gain with Coplanar Concentric Ring Patch Antenna", *Wireless Pers Commun*, vol. 108, pp. 1447-1457, 2019.
- [3] A. Al-Zoubi, F. Yang and A. Kishk, "A Broadband Center-Fed Circular Patch-Ring Antenna With a Monopole Like Radiation Pattern", *IEEE Transactions on Antennas and Propagation*, vol. 57, no. 3, pp. 789-792, March 2009.
- [4] G. K. Mishra, D. K. Upadhyay, J. Sahay, Sanjay Kumar, "Reconfigurable Bandpass filter for Bandwidth control in IMT-Advanced", *Microwave review*, vol 20, no. 02, pp. 09-13, December, 2014.
- [5] S. Shankar, D.K. Upadhyay, "A Compact Maple Leaf and Triangular Hybrid Fractal Shaped UWB Frequency Reconfigurable Antenna with Wide Continuous Tunable Band Notch," *Iranian Journal of Science and Technology, Transactions of Electrical Engineering*, vol. 47, pp. 301-316, 2023.
- [6] P. N. Suman and G. K. Mishra, "A CPW Fed Hexagonal Patch Frequency Reconfigurable Antenna For Multiple Applications", *Third International Conference on Advances in Electrical, Computing, Communication and Sustainable Technologies (ICAECT)*, Bhilai, India, pp. 1-3, 2023.
- [7] A. Al-Zoubi, F. Yang and A. Kishk, "A Broadband Center-Fed Circular Patch-Ring Antenna With a Monopole Like Radiation Pattern", *IEEE Transactions on Antennas and Propagation*, vol. 57, no. 3, pp. 789-792, March 2009.
- [8] A. Nella and A. S. Gandhi, "A Compact Novel Three-Port Integrated Wide and Narrow Band Antennas System for Cognitive Radio Applications", *International Journal of Antennas and Propagation*, pp. 1-4, 2016.
- [9] G. Jin, C. Deng, Y. Xu, J. Yang and S. Liao, "Differential Frequency-Reconfigurable Antenna Based on Dipoles for Sub-6 GHz 5G and WLAN Applications", *IEEE Antennas and Wireless Propagation Letters*, vol. 19, no. 3, pp. 472-476, March 2020.
- [10] H. A. Majid, M. K. A. Rahim, M. R. Hamid and M. F. Ismail "A Compact Frequency-Reconfigurable Narrowband Microstrip Slot Antenna", *IEEE Antennas and Wireless Propagation Letters*, vol. 11, pp. 616-619, 2012.
- [11] Y. Liu, P. Liu, Z. Meng, L. Wang and Y. Li, "A Planar Printed Nona-Band Loop-Monopole Reconfigurable Antenna for Mobile Handsets", *IEEE Antennas and Wireless Propagation Letters*, vol. 17, no. 8, pp. 1575-1579, Aug. 2018.
- [12] P. Nath Suman and G. Kant Mishra, "An Aperture Fed Frequency Reconfigurable Patch Antenna for X-Band Applications", *Second International Conference on Advances in Electrical, Computing, Communication and Sustainable Technologies (ICAECT)*, Bhilai, India, pp. 1-3, 2022.
- [13] X. L. Sun, S. W. Cheung, and T. I. Yuk, "Frequency-reconfigurable dual-band monopole antenna for WiMAX wireless devices", *Microwave and Optical Technology*, vol. 56, no. 1, pp. 49-55, Jan. 2014.
- [14] S. Subbaraj et al., "A Compact Frequency-Reconfigurable Antenna With Independent Tuning for Hand-Held Wireless Devices", *IEEE Transactions on Antennas and Propagation*, vol. 68, no. 2, pp. 1151-1154, Feb. 2020.
- [15] R. K. Chandan and S. Pal, "Development and Analysis of a HMSIW-Fed Broadband Superstrate Patch Array Using Dual-Resonance Mechanism for Ka-Band Applications ", *IEEE Antennas and Wireless Propagation Letters*, vol. 22, no. 4, pp. 849-853, April 2023.